

FHR系列低压储液回热器是为速冻机、速冻库和排管蒸发器的制冷装置等制冷剂充注量较大的系统设计的。

- 低压储液容积大，可以储存一定量未过热的制冷剂；
- 高效的热交换结构，容器内部的热交换管采用内/外螺纹高效紫铜管，具有强大的冷热交换能力。用从高压储液器供液管流入的制冷剂，与未过热的制冷剂进行热交换，制冷剂得到有效地过热的返回压缩机；
- 高效节能型设计，在高压液体制冷剂进入热力膨胀阀前使其过冷（焓值增加、避免出现闪发气体），可以大幅度提高压缩机的工作效率；
- 独特的U形管和回油孔设计，既保证了良好的回油效果，又可有效的避免液体制冷剂进入压缩机吸气管，避免压缩机液击；
- 设计压力：1.7 MPa；
- 适用制冷剂：R134a、R22、R407C、R404A、R507A；
- 连接口用途：(a)气进口，(b)气出口，(c)液进口，(d)液出口，(e)排污口，(f)安全阀口。

FHR Series low pressure liquid regenerator is designed for the systems who will be filled with large amount refrigerants, such as instant freezer、frozen storage and cooling grid.

- Large low pressure liquid storage volume, and it can store some non-overheat refrigerant;
- Efficient heat exchange structure, the inside heat exchange tube is high efficient copper tube who has internal and external thread., so it has strong heat exchange capability. The refrigerant from the liquid line of high pressure liquid receiver will make the heat exchange with the non-overheat refrigerant, and then the refrigerant will go back to the compressor after efficient overheat;
- Energy efficient design, it can make the high pressure liquid refrigerant to be supercooling before it enters into the thermostatic expansion valve (the enthalpy is increased and it can avoid flash gas), so the work efficiency of compressor can be improved greatly;
- With the special design of U shape tube and oil return hole, it can guarantee the perfect oil return and prevent the liquid refrigerant from entering into the compressor, so it can avoid liquid slugging to compressor;
- Design pressure: 1.7 MPa;
- Applicative refrigerants: R134a、R22、R407C、R404A、R507A;
- Connector application: (a)gas inlet,(b)gas outlet,(c)liquid inlet,(d)liquid outlet,(e)drain outlet,(f)Conn. for safety valve.

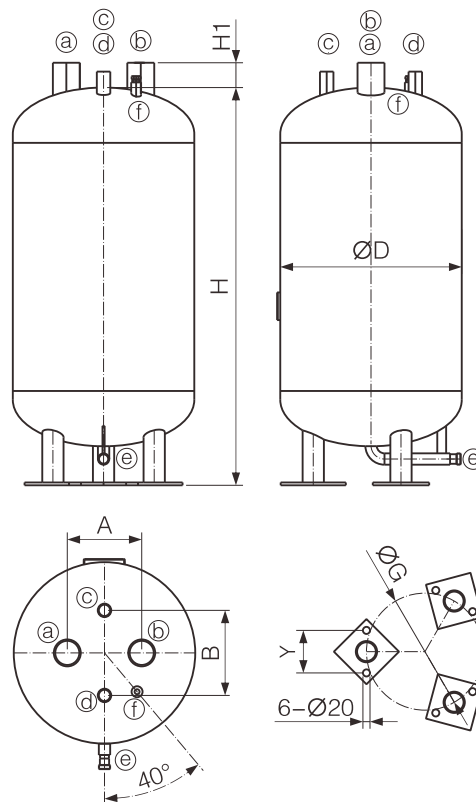

型号 Model	气管 Suction Pipe (mm)	液管 Liquid Pipe (mm)	ØD (mm)	H (mm)	H1 (mm)	A (mm)	B (mm)	Y (mm)	ØG (mm)	容积 Volume (l)	换热面积 Heat transfer area (m ²)
FHR-180	Ø76	Ø38	512	1122	70	210	250	120	330	180	1.17
FHR-245	Ø89	Ø45	562	1246	75	280	300	135	360	245	1.76
FHR-320	Ø108	Ø45	612	1356	100	308	300	135	400	320	2.20
FHR-467	Ø133	Ø57	712	1480	120	320	430	135	460	467	3.48
FHR-670	Ø159	Ø57	812	1652	180	432	460	160	520	670	4.13
FHR-1000	Ø219	Ø76	912	1882	180	414	560	160	580	1000	8.52